

Call: 800.882.9109 For Sizes



**1-3/4" & 2-1/4"
Hard Maple**

(all sizes available)

Top constructed from select northern hard maple, maximum length laminated strips, and finished with sealer and multiple coats of lacquer. Used in four station workbenches, wall benches, and heavy duty workbenches.

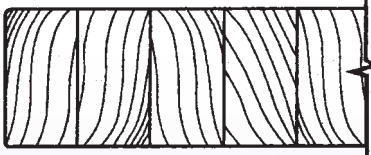

1-3/4" Bullnose Hard Maple *(all sizes available)*

Top constructed from select northern hard maple, maximum length laminated strips, with a rounded bullnose edge. Finished with sealer and multiple coats of lacquer. Used in child care, and office furniture.

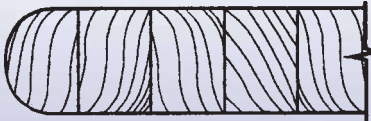

2" Steel Capped *(all sizes available)*

Heavy gauge steel top, folded all four sides, corners welded and ground smooth over a solid core. Used in metalworking benches, heavy duty workbenches, and machine shop benches.



3/4" Fiberesin *(all sizes available)*

Fiberesin is manufactured by a thermal fusing process which cures and permanently bonds melamine impregnated sheets directly to the surfaces of high density industrial grade particle board. Used mainly on drafting and computer tables.

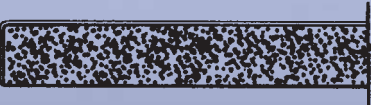

1-1/4" Chemsurf *(all sizes available)*

Chemsurf has a high resistance to chemical attack from organic solvents, alkalis, and acids. A composition of a special resin formulation is applied over phenolic-kraft core to produce a highly specialized pressure laminate bonded to medium density particle board.

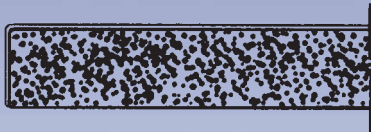

1" Epoxy Resin *(all sizes available)*

1" epoxy resin is impervious to normal laboratory chemicals and heat. Its monolithic composition eliminates the possibility of swelling, delamination, and exposure of the substrate. Its soft, low glare surface is simple to clean. Epoxy resin exhibits no effect when subjected to these common laboratory chemicals, Nitric Acid 70%, Acetic Acid (glacial), Hydrochloric Acid 20%, Sulfuric Acid 60%, Methyl Alcohol, Toluene, Benzene, and others. Epoxy resin is solid, homogeneous, molded from modified epoxy resins, completely oven cured during processing. It is durable and impervious to moisture. Exposed edges and corners are finished with a 1/8" bevel. Color: black.

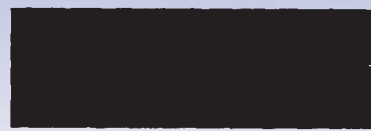

Top Options

CF	Cedarquist fastener for joining tops (factory installed).....	Each
DHV	Drilling for vise attachments	Per Vise
BS	Bench stop - 3/4" post.....	Each
DHBS	Holes drilled for bench stops.....	Per Hole
A1-2X2	Angle Iron 2" x 2" x 3/16" - (factory installed).....	Per Ln. Ft.
BS-4	4" Backsplash (1" thick) shipped detached w/top	Per Ln. Ft.

Wall & Open Storage Cabinets



Casework

Base and wall cabinets are constructed of solid maple framing with birch plywood sides using mortise and tenon joint construction. Locks available for all doors. Finish consists of sealer with multiple coats of lacquer.

Wall Mounted Cabinets

All wall cabinets are 30"H. Interior is birch plywood. Product number indicates depth and width.

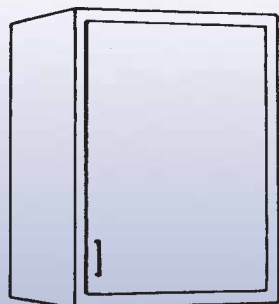

One Door Unit

With two adjustable shelves.

WM1-12x18 WM1-16x18
WM1-12x24 WM1-16x24

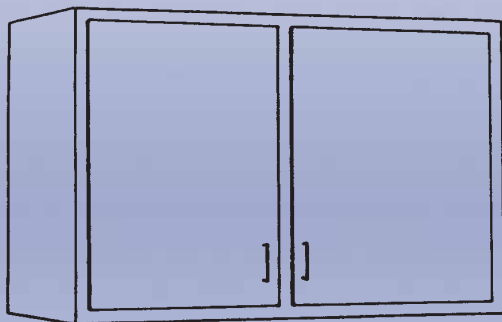

Two Door Unit

With two adjustable shelves.

WM2-12x35 WM2-12x47 WM2-16x35 WM2-16x47

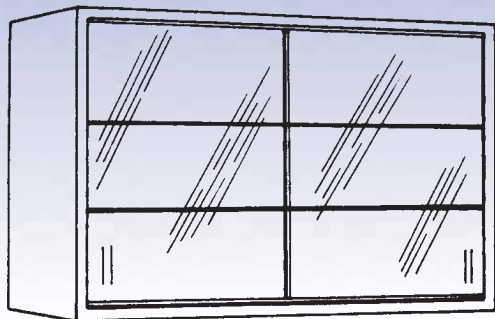

Two Door Sliding Glass Unit

With two adjustable shelves. Available with glass or plexiglass doors. Please specify glass or plexiglass when ordering.

WM3-12x35 WM3-12x47 WM3-16x35 WM3-16x47

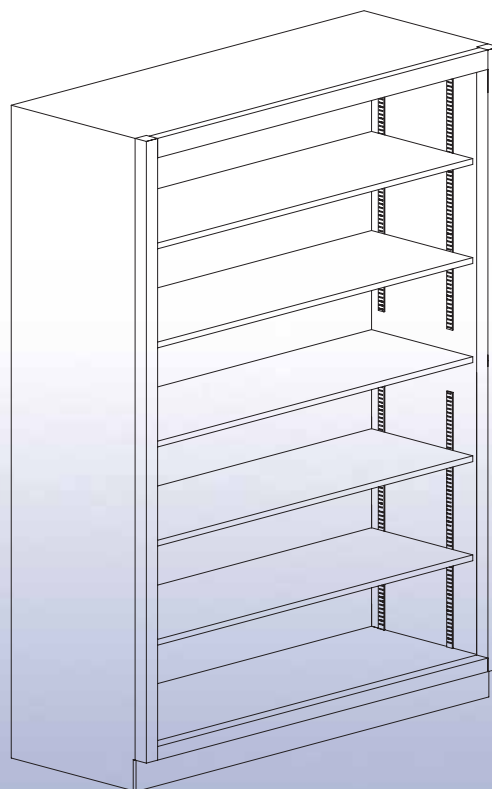

Open Shelf Tall Storage

84" High with birch back. Five adjustable shelves.

OS-1409	12"D x 35"W	OS-1420	16"D x 47"W
OS-1413	12"D x 47"W	OS-1426	22"D x 35"W
OS-1419	16"D x 35"W	OS-1427	22"D x 47"W

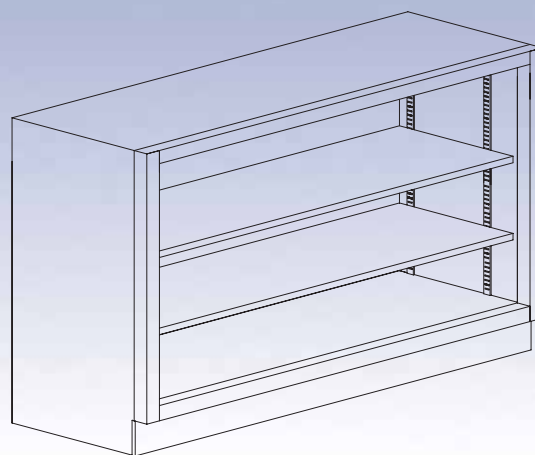

Open Shelf Storage

34-3/4" High with birch back. Two adjustable shelves.

OS-1702	12"D x 35"W	OS-1706	16"D x 47"W
OS-1703	12"D x 47"W	OS-1403	22"D x 35"W
OS-1705	16"D x 35"W	OS-1404	22"D x 47"W



Casework

We provide a wide variety of low and high base cabinets. Base and wall cabinets are constructed of solid maple framing with birch plywood sides using mortise and tenon joint construction. All drawers are constructed using dovetail construction. Masterkeyed cylinder locks are available for all doors and drawers. Finish consists of sealer with multiple coats of lacquer.

Wood Sitting Height Base Cabinets

Bases are all constructed of solid maple framing with birch plywood panel sides utilizing mortise and tenon joint construction. Drawers are constructed using dovetail construction. Finish consists of sealer with multiple coats of lacquer. A wide variety of tops (see page 60), can be used to enhance these units. Locks, finished backs, and extended bases can be furnished at an additional cost--contact Shain for pricing. All units are 23"D x 29-3/4"H. Last two numbers indicate unit width. Units come with toe kicks unless specified. Tops not included.

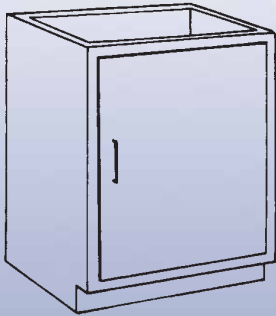

Adjustable Shelf Unit

WLB-11x18
WLB-11x24



Build Your Own Mobile Unit

Shain will help you custom design units that meet your needs. Add a top, casters, locks, etc. Call for details.

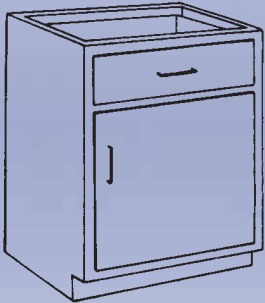

One Drawer, One Door Unit

WLB-12x18
WLB-12x24

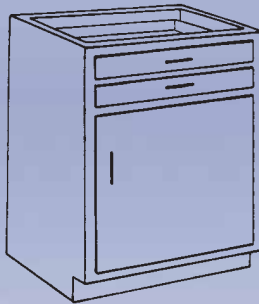

Two Drawer, One Door Unit

WLB-13x18
WLB-13x24

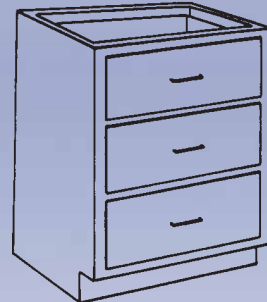

Three Drawer Unit

WLB-10x18
WLB-10x24

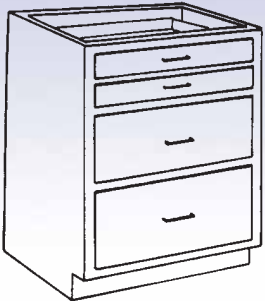

Four Drawer Unit Two Shallow, Two Deep

WLB-18x18
WLB-18x24

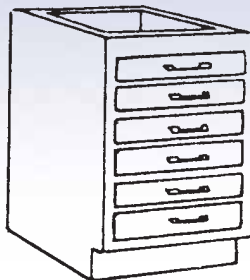

Six Drawer Unit

WLB-23x18
WLB-23x24

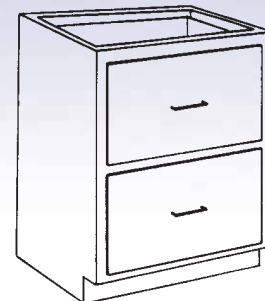

Two File Drawer Unit

WLB-16x18
WLB-16x24

Low Base Cabinets

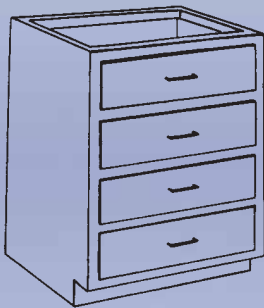

Four Drawer Unit
WLB-14x18 WLB-14x24

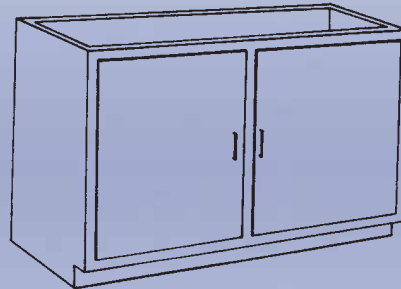

Two Door Unit with Adjustable Shelf
WLB-31x35 WLB-31x47

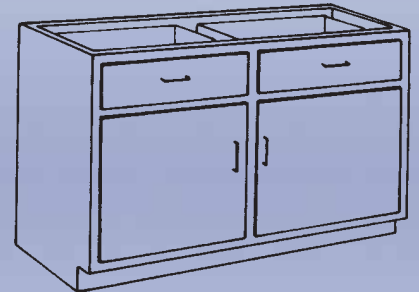

Two Door, Two Drawer Unit
WLB-32x35 WLB-32x47

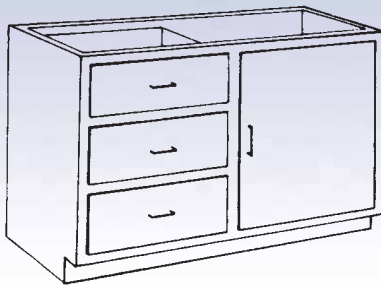

One Door, Three Drawer Unit with Adjustable Shelf.
WLB-37x35 WLB-37x47

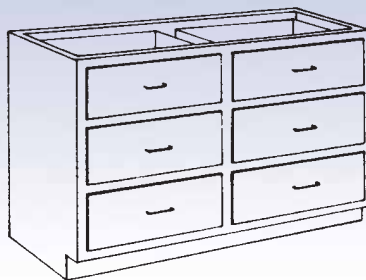

Six Drawer Unit
WLB-30x35 WLB-30x47

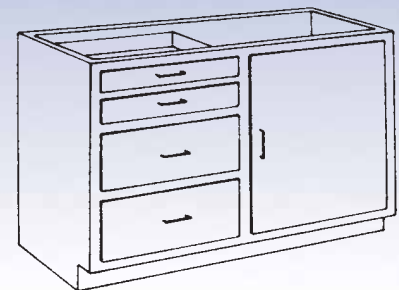

One Door, Four Drawer Unit
With adjustable shelf, two shallow drawers, and two deep drawers.
WLB-38x35 WLB-38x47

High Base Cabinets



Wood Standing Height Base Cabinets

Bases are all constructed of solid maple framing with birch plywood panel sides utilizing mortise and tenon joint construction. Drawers are constructed using dovetail construction. Finish consists of sealer with multiple coats of lacquer. A wide variety of tops (see page 60), can be used to enhance these units. Locks, finished backs, and extended bases can be furnished at an additional cost--contact Shain for pricing. All units are 23"D x 34-3/4"H. Last two numbers indicate unit width. Tops not included.

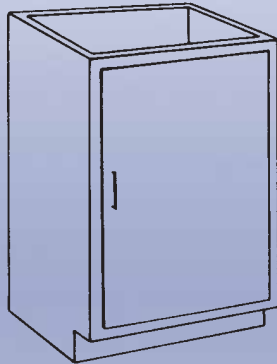

One Door Unit

With two adjustable shelves
WHB-121x24

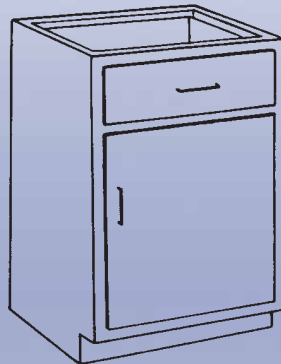

One Drawer, One Door Unit

With one adjustable shelf
WHB-122x24

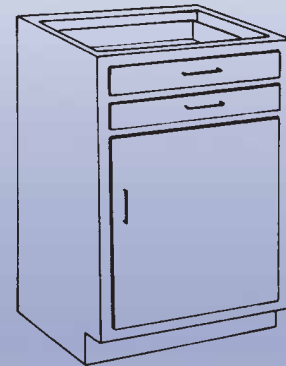

Two Drawer, One Door Unit

With one adjustable shelf
WHB-113x24

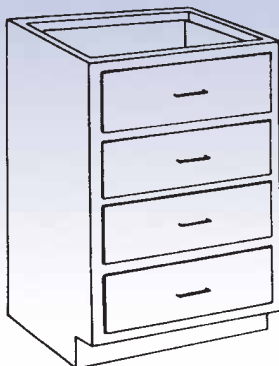

Four Drawer Unit

WHB-120x24

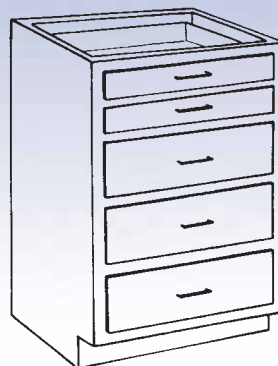

Five Drawer Unit

Two shallow and three deep drawers.
WHB-118x24

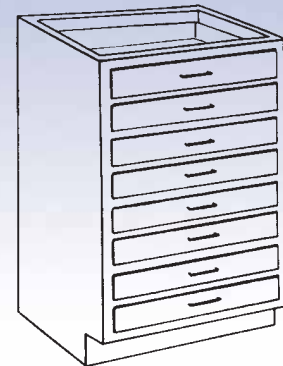

Eight Drawer Unit

WHB-123x24

High Base Cabinets



Casework

Base and wall cabinets are constructed of solid maple framing with birch plywood sides using mortise and tenon joint construction. All drawers are constructed using dovetail construction. Masterkeyed cylinder locks available for all doors and drawers. Finish consists of sealer with multiple coats of lacquer.

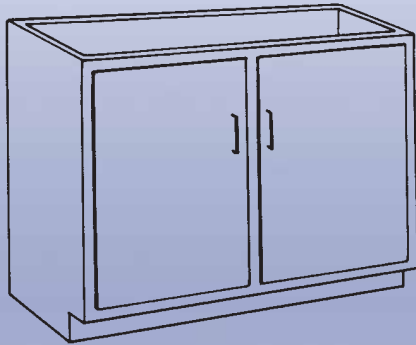

Two Door Unit

With two adjustable shelves.
WHB-131x35 WHB-131x47

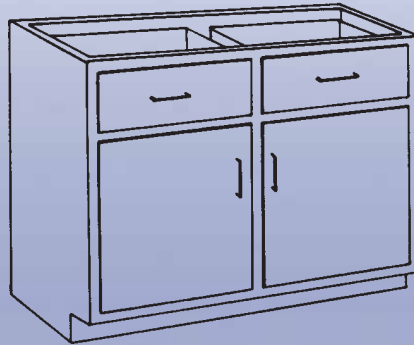

Two Drawer, Two Door Unit

With one adjustable shelf.
WHB-132x35 WHB-132x47

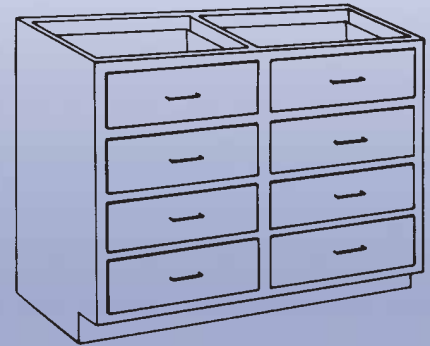

Eight Drawer Unit

WHB-140x35 WHB-140x47

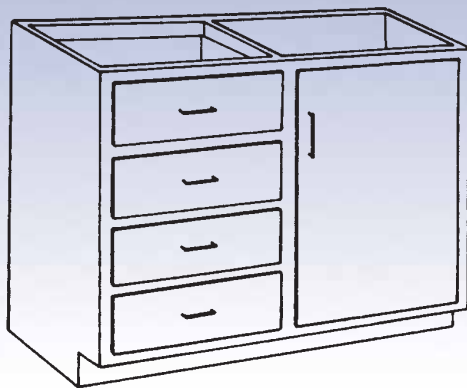

Four Drawer, One Door Cabinet

With two adjustable shelves.
WHB-137x35 WHB-137x47

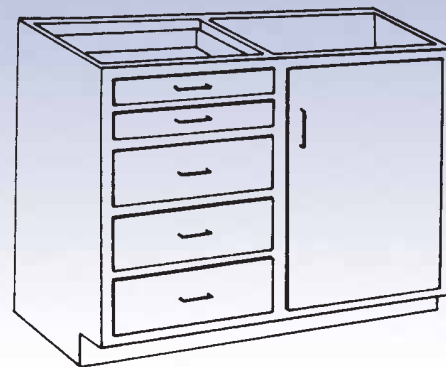

Five Drawer, One Door Cabinet

With two adjustable shelves, two shallow and three deep drawers.
WHB-138x35 WHB-138x47

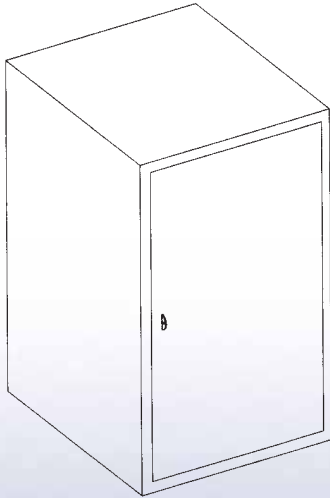

Single Door Locker Base

Heavy gauge steel unit, welded and riveted throughout. Has single door with one adjustable shelf. Doors have spring loaded hinges, padlock hasp, and knockout plug for cylinder lock. Color: gray. Overall size: 18"W x 21"D x 31"H.

LB-D1 Single Door Locker Base
CL-MD Optional Cylinder Lock and Key
NP Optional Number Plate

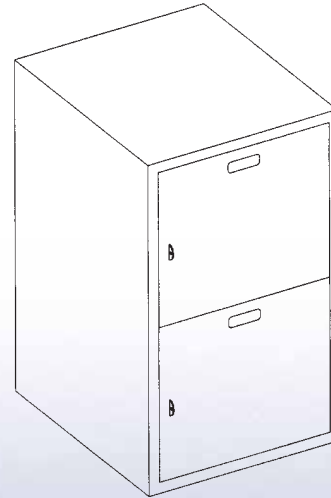

Locker Base

Heavy gauge steel unit, welded and riveted throughout, contains two locker openings (18"W x 21"D x 15"H). Doors have spring loaded hinges, padlock hasp, and knockout plug for cylinder locks. Color: gray. Overall size: 18"W x 21"D x 31"H.

LB-B2 Locker Base
CL-MD Optional Cylinder Lock and Key
NP Optional Number Plate

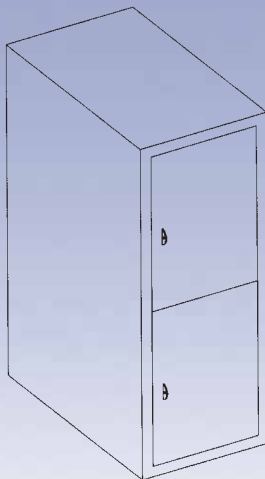

Locker Base

Heavy gauge steel unit, welded and riveted throughout, contains two locker openings (12"W x 21"D x 15"H). Doors have spring loaded hinges, padlock hasp, and knockout plug for cylinder locks. Color: gray. Overall size: 12"W x 21"D x 31"H.

LB-2 Locker Base
CL-MD Optional Cylinder Lock and Key
NP Optional Number Plate

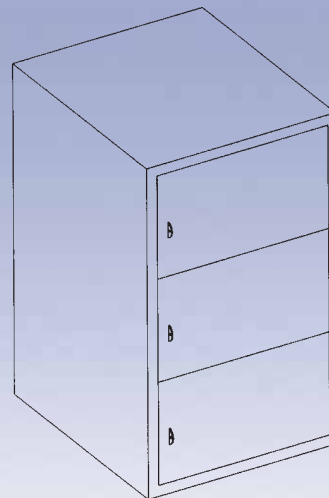

Locker Base

Heavy gauge steel unit, welded and riveted throughout, contains three locker openings (18"W x 21"D x 10"H). Doors have spring loaded hinges, padlock hasp, and knockout plug for cylinder locks. Color: gray. Overall size: 18"W x 21"D x 31"H.

LB-6A3 Locker Base
CL-MD Optional Cylinder Lock and Key
NP Optional Number Plate

Metal Base Units

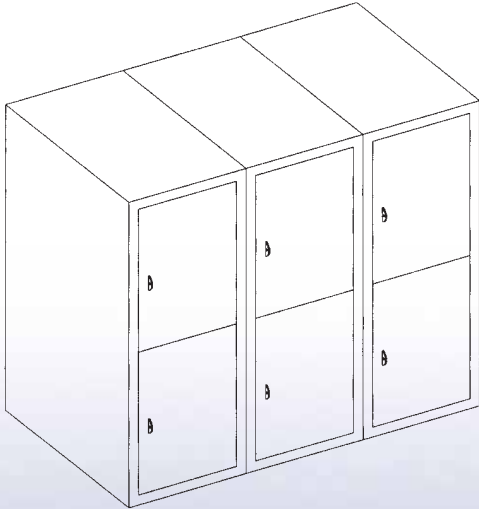

Vertical Locker Base

Heavy gauge steel unit, welded and riveted throughout, six locker openings (12" W x 21"D x 15"H). Doors have spring loaded hinges, padlock hasp, and knockout plug for cylinder locks. Color: gray. Overall size: 36"W x 21"D x 31"H.

- LB-6 Vertical Locker Base
- CL-MD Optional Cylinder Lock and Key
- NP Optional Number Plate

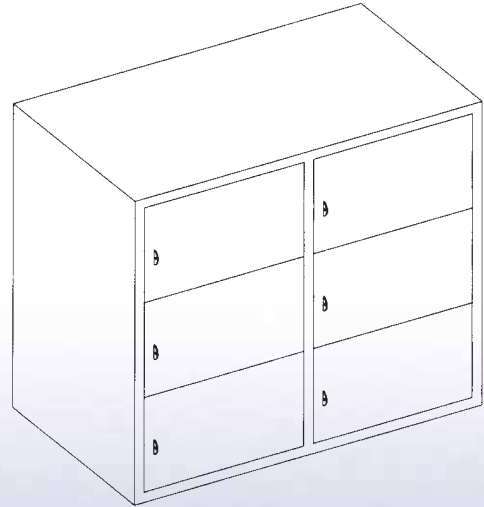

Horizontal Locker Base

Heavy gauge steel unit, welded and riveted throughout, six locker openings (18" W x 21"D x 10"H). Doors have spring loaded hinges, padlock hasp, and knockout plug for cylinder locks. Color: gray. Overall size: 36"W x 21"D x 31"H.

- LB-6A Horizontal Locker Base
- CL-MD Optional Cylinder Lock and Key
- NP Optional Number Plate

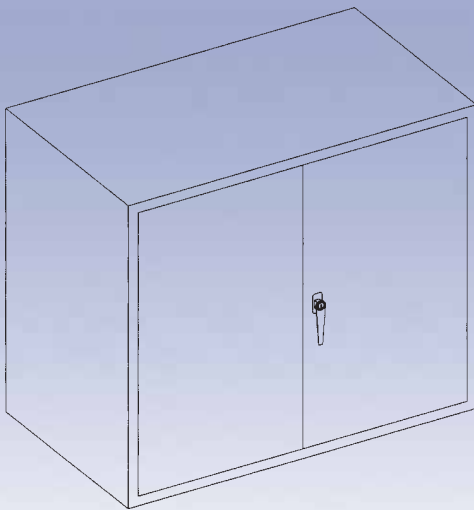

Double Door Locker Base

Heavy gauge steel unit, welded and riveted throughout. Has double swinging doors with cylinder lock mounted in chrome handle with two point locking device, and one adjustable shelf. Color: gray. Overall size: 36"W x 21"D x 31"H.

- LB-D2 Double Door Locker Base
- NP Optional Number Plate

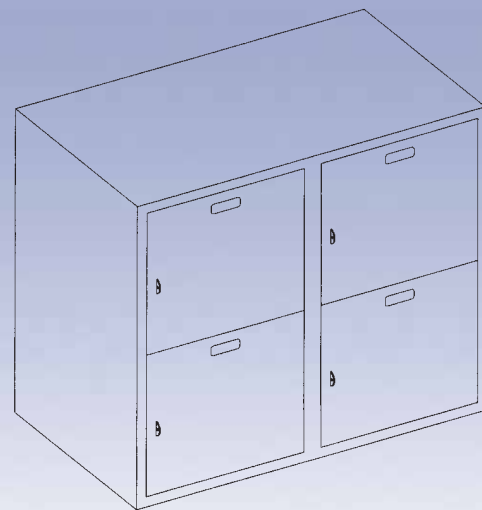

Locker Base

Heavy gauge steel unit, welded and riveted throughout, four locker openings (18" W x 21"D x 15"H). Doors have spring loaded hinges, padlock hasp, and knockout plug for cylinder locks. Color: gray. Overall size: 36"W x 21"D x 31"H.

- LB-B4 Locker Base
- CL-MD Optional Cylinder Lock and Key
- NP Optional Number Plate