



Mobile Tote Tray Cabinet

Unit is constructed of solid maple framing with birch plywood panel sides and back utilizing mortise and tenon joint construction. Unit includes 24 tote trays (4" x 13" x 19"), set of casters, and masterkeyed lock. Finish consists of sealer and multiple coats of lacquer. Overall size: 47"W x 22"D x 51"H.

MTTC-4824WD Mobile Tote Tray Cabinet



Mobile Tote Tray Cabinet

Unit is constructed of solid maple framing with birch plywood panel sides and back utilizing mortise and tenon joint construction. Unit includes: adjustable shelves, ten tote trays (4" x 13" x 19"), and set of casters. Finish consists of sealer and multiple coats of lacquer. Overall size: 47"W x 22"D x 36"H.

MTTC-3410 Mobile Tote Tray Cabinet



Mobile Tote Tray Cabinet

Unit is constructed of solid maple framing with birch plywood panel sides and back utilizing mortise and tenon joint construction. Unit includes: three adjustable shelves, 16 tote trays (4" x 13" x 19"), set of casters, and masterkeyed lock. Finish consists of sealer and multiple coats of lacquer. Overall size: 47"W x 22"D x 51"H.

MTTC-4816WD Mobile Tote Tray Cabinet



Mobile Tote Tray Cabinet

Unit is constructed of solid maple framing with birch plywood panel sides and back utilizing mortise and tenon joint construction. Unit includes 15 tote trays (4" x 13" x 19") and set of casters. Finish consists of sealer and multiple coats of lacquer. Overall size: 47"W x 22"D x 36"H.

MTTC-3415 Mobile Tote Tray Cabinet



Mobile Tote Tray Storage Cabinet

Unit is constructed of solid maple framing with birch plywood panel sides, back, and doors utilizing mortise and tenon joint construction. Unit includes one full shelf, 24 tote trays (4" x 8" x 19"), casters, pulls, and masterkeyed cylinder lock. Finish consists of sealer and multiple coats of lacquer. Overall size: 47"W x 22"D x 66"H.

MTTC-230 **Mobile Tote Tray Storage Cabinet**



Mobile Storage Cabinet

Cabinet is constructed of solid maple framing with birch plywood panel sides, back, and doors utilizing mortise and tenon joint construction. Unit comes complete with pegboard (tool hooks included), full width adjustable shelves, and tote trays (4" x 8" x 19"). Pulls, masterkeyed lock, and four casters are included. Finish consists of sealer and multiple coats of lacquer. Overall size: 47"W x 22"D x 66"H.

MTC-200 **Mobile Storage Cabinet**

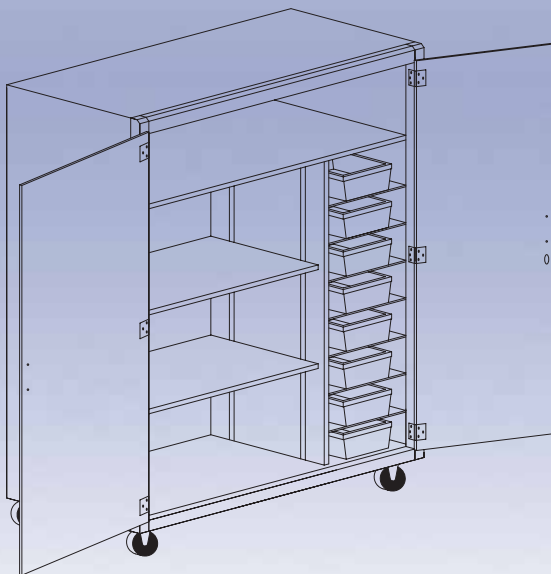

Mobile Tote Tray/Shelf Storage Cabinet

Unit is constructed of solid maple framing with birch plywood panel sides, back, and doors utilizing mortise and tenon joint construction. Unit includes one full shelf, two adjustable partial shelves, eight tray storage compartments with tote trays (4" x 8" x 19"), casters, pulls, and masterkeyed lock. Finish consists of sealer and multiple coats of lacquer. Overall size: 47"W x 22"D x 66"H.

MTTC-231 **Mobile Tote Tray/Shelf Storage Cabinet**



Mobile Shelf Storage Cabinet

Unit is constructed of solid maple framing with birch plywood panel sides, back, and doors utilizing mortise and tenon joint construction. Unit includes full adjustable shelves, pulls, masterkeyed lock, and casters. Finish consists of sealer and multiple coats of lacquer. Overall size: 47"W x 22"D x 66"H.

MSSC-200 **Mobile Shelf Storage Cabinet**



Mobile Cart

Open style cart is constructed of square maple legs, 4" apron and stringers utilizing mortise and tenon joint construction with draw bolt reinforcement. Unit includes lower birch plywood shelf and locking swivel casters. Finish consists of sealer and multiple coats of lacquer. Top is constructed of 1-1/4" black Chemsurf. Overall size: 36"W x 24"D x 30"H.

PDC-2436 Demonstration Cart



Mobile Demo Cabinet

Designed to serve as demonstration bench, transport equipment and supplies or store reference materials. Base constructed of solid maple framing with birch plywood panel sides and back utilizing mortise and tenon joint construction. Comes with one adjustable shelf. Finish consists of sealer and multiple coats of lacquer. Top is 1-1/4" black Chemsurf. Overall size: 36"W x 24"D x 32-1/2"H.

MDC-2436C Open Front Mobile Demo Cabinet

Mobile Demo Cabinet

Designed to serve as an instructor's demonstration bench, transport equipment and supplies or store reference materials. Base constructed of solid maple framing with birch plywood panel sides and back utilizing mortise and tenon joint construction. Comes with one adjustable shelf. Model has double doors with lock. Finish consists of sealer and multiple coats of lacquer. Top is 1-1/4" black Chemsurf. Overall size: 36"W x 24"D x 32-1/2"H.

EMDC-2436C Door Front Mobile Demo Cabinet



Mobile Demo Cart

Flexible work bench can be used anywhere from the kitchen, to the workshop, to the classroom. Moves easily from room to room on casters. Base constructed

of solid maple framing using mortise and tenon joint construction. Unit consists of a double door cabinet with adjustable shelf and birch plywood panels on doors, sides, and back. Two built-in angled pegboard panels provide visible storage area of tools. Top constructed of 1-3/4" maple. Finish consists of sealer and multiple coats of lacquer. Overall size: 60"W x 28"D x 28-1/4"H.

EMWB-6 Mobile Work Bench

Heavy Duty Service Cart

Constructed of ribbed steel angle posts, and steel trays with 3" depth mitred flanges. 800 lbs. capacity. Can be inverted for flat work surface. Has tubular steel push handle, baked gray enameled rust-resistant finish. Mounted on casters. Option to add another shelf. Color: gray. Available in two different sizes.

- MSC-250 Cart (30"W x 16"D x 32"H)**
- MSC-252 Cart with Extra Shelf (30"W x 16"D x 32"H)**
- MSC-251 Cart (36"W x 24"D x 32"H)**
- MSC-253 Cart with Extra Shelf (36"W x 24"D x 32"H)**





Mobile Cabinet

Constructed of solid maple framing with birch plywood sides and back utilizing mortise and tenon joint construction. Right side fitted with 1/8" pegboard and hooks for tool mounting. Unit

includes double door cabinet with adjustable shelf, masterkeyed locks, and set of casters. Finish consists of sealer and multiple coats of lacquer. Top constructed of 1-3/4" thick maple. Overall size: 36"W x 24"D x 34"H.

WMSC-3135 Mobile Cabinet



Mobile Cabinet

Constructed of solid maple framing with birch plywood sides and back utilizing mortise and tenon joint construction. Right side fitted with 1/8" pegboard and hooks for tool mounting. Unit includes three drawers (14"W x 18"D x 5"H), single door with adjustable shelf, masterkeyed locks, and set of casters. Finish consists of sealer and multiple coats of lacquer. Top constructed of 1-3/4" maple. Overall size: 36"W x 24"D x 34"H.

WMSC-3735 Mobile Cabinet

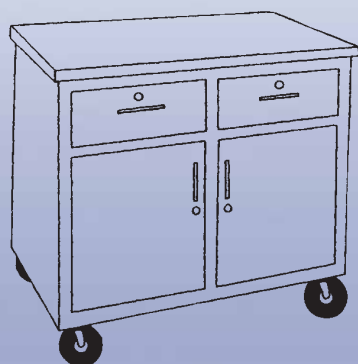

Mobile Cabinet

Constructed of solid maple framing with birch plywood sides and back utilizing mortise and tenon joint construction. Right side fitted with 1/8" pegboard and hooks for tool mounting. Unit includes two draw-

ers (14"W x 18"D x 5"H), double door, masterkeyed locks, and set of casters. Finish consists of sealer and multiple coats of lacquer. Top constructed of 1-3/4" maple. Overall size: 36"W x 24"D x 34"H.

WMSC-3235 Mobile Cabinet

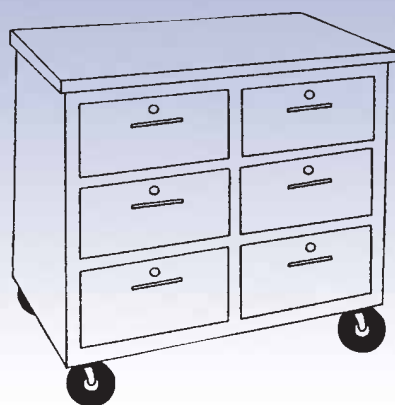

Mobile Cabinet

Constructed of solid maple framing with birch plywood sides and back utilizing mortise and tenon joint construction with right side fitted with 1/8" pegboard and hooks for tool mount-

ing. Unit includes six drawers (14"W x 18"D x 5"H). All drawers constructed using dovetail joint construction with pulls, masterkeyed locks, and set of casters. Top constructed of 1-3/4" maple. Finish consists of sealer and multiple coats of lacquer. Overall size: 36"W x 24"D x 34"H.

WMSC-3035 Mobile Cabinet



Mobile Storage Cabinet

Efficient orderly method of storing classroom supplies like papers, markers, paints, etc. Unit constructed of solid maple framing with birch veneered paneling. Includes four drawers (14"W x 18"D x 5"H), and a cupboard with adjustable shelves, large tote trays, set of casters and masterkeyed locks. Top is 1-1/4" plastic laminate. Finish consists of sealer and multiple coats of lacquer. Overall size: 36"W x 24"D x 36-3/4"H.

MAC-137P Mobile Storage Cabinet

Mobile Multimedia

Designed for multimedia on the go! When you require maximum size and stability, the Mobile Multimedia cart provides a total media solution. This unit can hold a wide variety of devices for video, audio, and computer based applications. The base is constructed of select hardwood and the top of durable high-pressure laminate with 3mm edging. Constructed of solid hardwood legs and truss bar utilizing mortise and tenon construction with draw bolt reinforcement. The top is 3/4" high-pressure laminate (36"W x 30"D) with 3mm edge banding. The lower shelf is hardwood veneer (30"W x 15"D) with front and back curb. The unit also includes easy glide, total locking casters. Finish consists of sealer with multiple coats of lacquer. Options include a keyboard tray and mouse deck. Overall size: 36"W x 30"D x 36"H.

MMM-1 Mobile Multimedia



Accessories:

KBMD Keyboard Tray & Mouse Deck

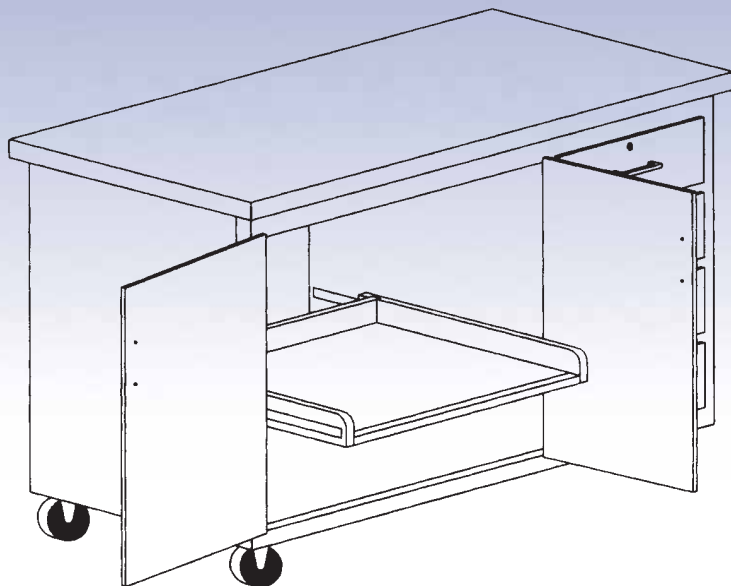

Mobile Storage/Demo Bench

Constructed of solid maple framing with birch plywood panel sides and back. Base consists of four drawers (13-3/8"W x 18"D x 5"H), and cabinet area with full suspension shelf. All drawers constructed using dovetail joint construction with pulls and masterkeyed cylinder locks. Unit supplied with electrical outlet box with fuse and switch, set of casters, and back covered with cork. Finish consists of sealer with multiple coats of lacquer. Top is 1-3/4" solid maple. Overall size: 48"W x 24"D x 37-3/4"H.

PDB-20 Mobile Storage/Demo Bench